

10Gb/s SFP+ SDH/SONET Optical Transceiver Module

TR-PX13L-xSN

Features

- 10Gb/s serial optical interface compliant to SONET OC192/SDH STM64 and 802.3ae
- Hardware/Software Rate select function for 8.5G and 9.95~11.3G data rate
- 1310nm DFB transmitter, PIN photo-detector
- 2-wire interface for management specifications compliant with SFF 8472 digital diagnostic monitoring interface for optical transceivers
- Operating case temperature:
 - TR-PX13L-NSN, 0°C to 70°C
 - TR-PX13L-MSN, -5°C to 85°C
 - TR-PX13L-VSN, -40°C to 85°C
- Built-in CDR on RX side with very low jitter (<0.18UI) enabling direct and longer connection between transceiver module and host board ASIC
- Built-in CDR on TX side with high input jitter (up to 0.61UI) allowing direct link from host board ASIC to module



Applications

- SONET(OC-192)/SDH(STM64) line card
- 10GBASE-LR (10.3125Gbps)
- 10GBASE-LW (9.953Gbps)
- 8.5 Gb/s Fiber Channel
- 10.5Gb/s Fiber Channel
- High-speed storage area networks
- Computer cluster cross-connect

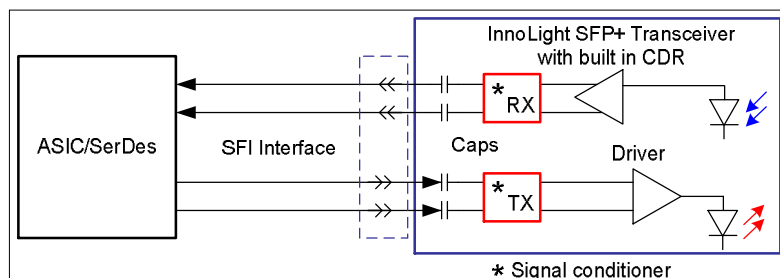

Figure1: Application

1. GENERAL DESCRIPTION

The TR-PX13L-xSN is a very compact 10Gb/s optical transceiver module for serial optical communication applications at 10Gb/s. The TR-PX13L-xSN converts a 10Gb/s serial electrical data stream to 10Gb/s optical output signal and a 10Gb/s optical input signal to 10Gb/s serial electrical data streams. The high speed 10Gb/s electrical interface is fully compliant with XFI specification (built in CDR on both TX and RX) and allows FR4 host PCB trace up to 200mm. The TR-PX13L-xSN is designed for use in a variety of 10Gb/s equipment SDH/SONET (9.95 Gb/s), Ethernet LAN (10.3Gb/s) and FC (8.5Gb/s and 10.5Gb/s). The high performance 1310nm DFB transmitter coupled with a high sensitivity PIN receiver provide superior performance for applications up to 10km SMF. The fully compliant SFP form factor provides high density applications, hot pluggability, easy optical port upgrades and low EMI emission.

The SFP+ LR w/CDR module electrical interface is compliant to XFI electrical specifications. The transmitter input and receiver output impedance is 100 Ohms differential. Data lines are internally AC coupled. The module provides differential termination and reduce differential to common mode conversion for quality signal termination and low EMI. XFI typically operates over 200 mm of improved FR4 material or up to about 150mm of standard FR4 with one connector.

The transmitter converts 10Gbit/s serial PECL or CML electrical data into serial optical data compliant with the 10GBASE-LR standard. An open collector compatible Transmit Disable (Tx_Dis) is provided. A logic "1," or no connection on this pin will disable the laser from transmitting. A logic "0" on this pin provides normal operation. The transmitter has an internal automatic power control loop (APC) to ensure constant optical power output across supply voltage and temperature variations. An open collector compatible Transmit Fault (Tx_Fault) is provided. Tx_Fault is a module output contact that when high, indicates that the module transmitter has detected a fault condition related to laser operation or safety. The Tx_Fault output contact is an open drain/collector and shall be pulled up to the Vcc_Host in the host with a resistor in the range 4.7-10 kΩ. Tx_Disable is a module input contact. When Tx_Disable is asserted high or left open, the SFP+ module transmitter output shall be turned off. This contact shall be pulled up to VccT with a 4.7 kΩ to 10 kΩ resistor

The receiver converts 10Gbit/s serial optical data into serial PECL/CML electrical data. An open collector compatible Loss of Signal is provided. Rx_LOS when high indicates an optical signal level below that specified in the relevant standard. The Rx_LOS contact is an open drain/collector output and shall be pulled up to Vcc_Host in the host with a resistor in the range 4.7-10 kΩ, or with an active termination. Power supply filtering is recommended for both the transmitter and receiver. The Rx_LOS signal is intended as a preliminary indication to the system in which the SFP+ is

installed that the received signal strength is below the specified range. Such an indication typically points to non-installed cables, broken cables, or a disabled, failing or a powered off transmitter at the far end of the cable.

2. PROPOSED APPLICATION SCHEMATICS

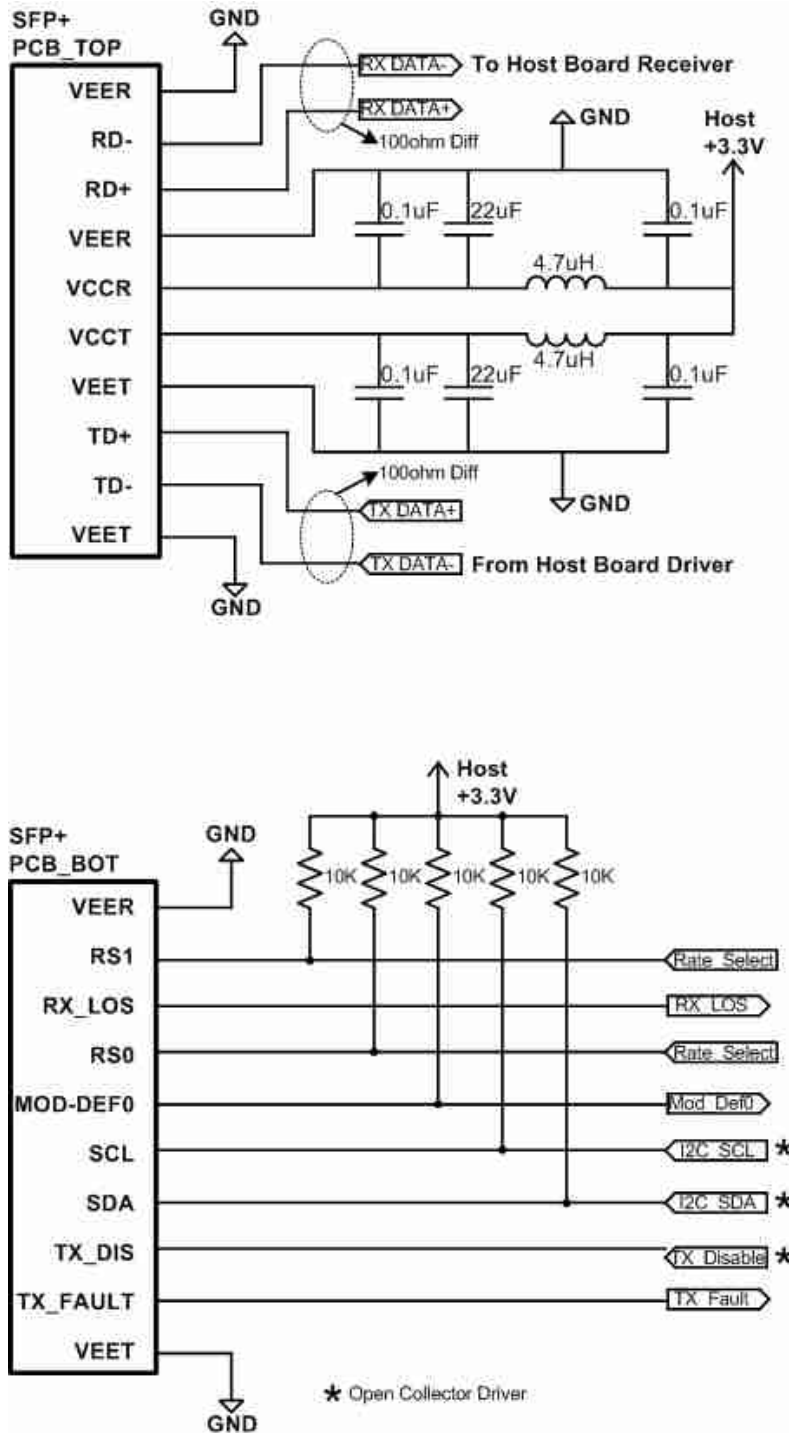

3. PIN DEFINITION

The SFP+ modules are hot-pluggable. Hot pluggable refers to plugging in or unplugging a module while the host board is powered. The SFP+ host connector is a 0.8 mm pitch 20 position right angle improved connector specified by SFF-8083, or stacked connector with equivalent electrical performance. Host PCB contact assignment is shown in Figure 2 and contact definitions are given in Table 2. SFP+ module contacts mates with the host in the order of ground, power, followed by signal as illustrated by Figure 3 and the contact sequence order listed in Table 2.

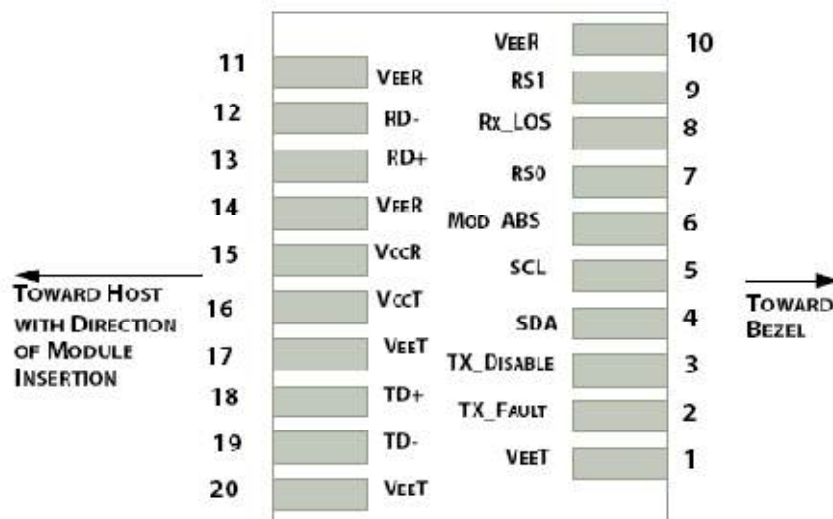

Figure 2: Module Interface to Host

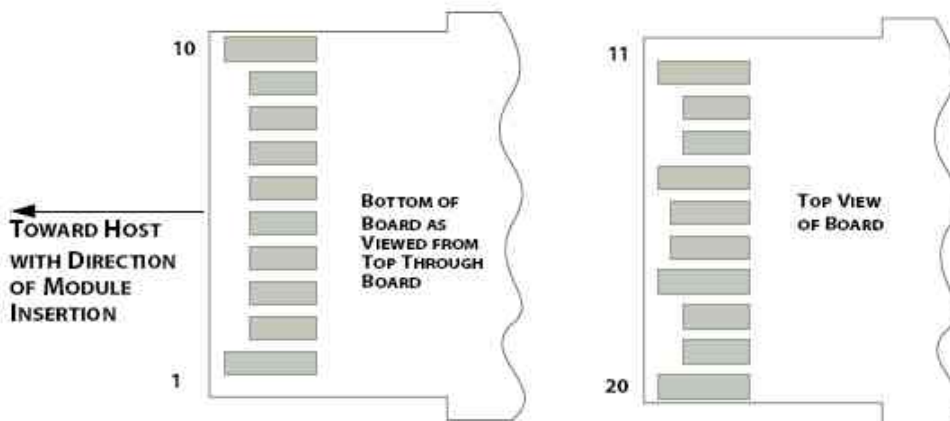

Figure 3: Module Contact Assignment

PIN	Logic	Symbol	Name / Description	Note
1		VeeT	Module Transmitter Ground	1
2	LVTTL-O	TX_Fault	Module Transmitter Fault	
3	LVTTL-I	TX_Dis	Transmitter Disable; Turns off transmitter laser	
4	LVTTL-I/O	SDA	2-Wire Serial Interface Data Line	2
5	LVTTL-I	SCL	2-Wire Serial Interface Clock	2
6		MOD_DEF0	Module Definition, Grounded in the module	
7	LVTTL-I	RS0	Rate Select	3
8	LVTTL-O	RX_LOS	Receiver Loss of Signal Indication Active High	
9	LVTTL-I	RS1	Rate Select	3
10		VeeR	Module Receiver Ground	1
11		VeeR	Module Receiver Ground	1
12	CML-O	RD-	Receiver Inverted Data Output	
13	CML-O	RD+	Receiver Data Output	
14		VeeR	Module Receiver Ground	1
15		VccR	Module Receiver 3.3 V Supply	
16		VccT	Module Receiver 3.3 V Supply	
17		VeeT	Module Transmitter Ground	1
18	CML-I	TD+	Transmitter Non-Inverted Data Input	
19	CML-I	TD-	Transmitter Inverted Data Input	
20		VeeT	Module Transmitter Ground	1

Table 2: SFP+ Module PIN Definition

Note:

1. Module ground pins GND are isolated from the module case.
2. Shall be pulled up with 4.7K-10Kohms to a voltage between 3.15V and 3.45V on the host board.
3. when RS0=0 RS1=0, 8G FC for both Tx and Rx
 when RS0=0 RS1=1, Bypassing CDR in both Rx and Tx
 when RS0=1 RS1=0, Bypassing CDR in both Rx and Tx
 when RS0=1 RS1=1, 9.95Gbps to 11.3Gbps for both Tx and Rx.

4. TRANSCEIVER BLOCK DIAGRAM

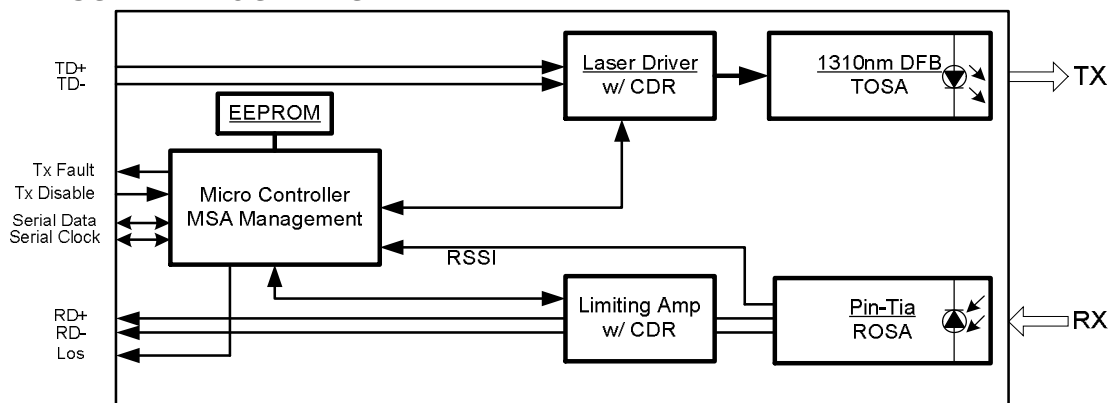

5. ABSOLUTE MAXIMUM RATING

These values represent the damage threshold of the module. Stress in excess of any of the individual Absolute Maximum Ratings can cause immediate catastrophic damage to the module even if all other parameters are within Recommended Operating Conditions.

Parameters	Symbol	Min.	Max.	Unit
Power Supply Voltage	VCC	0	3.6	V
Storage Temperature	Tc	-40	85	°C
Operating Case Temperature	Tc	-40	85	°C
Relative Humidity	RH	5	95	%
RX Input Average Power	Pmax	-	0	dBm

Table 3: Absolute Maximum Rating

6. RECOMMENDED OPERATING ENVIRONMENT

Recommended Operating Environment specifies parameters for which the electrical and optical characteristics hold unless otherwise noted.

Parameters	Symbol	Min.	Typical	Max	Unit
Power Supply Voltage	VCC	3.135	3.3	3.465	V
Power Supply Current	Icc			360	mA
Operating Case Temperature, NSN	TC-N	0	25	70	°C
Operating Case Temperature, MSN	TC-M	-5	25	85	°C
Operating Case Temperature, VSN	TC-V	-40	25	85	°C

Table 4: Recommended Operating Environment

7. Optical Interface

Transmitter Optical Interface						
Parameter	Symbol	Min	Typical	Max	Unit	Note
Operating Data Rate	-	9.95		11.3	Gb/s	1
Output Center Wavelength	l _{tc}	1290	1310	1330	nm	
Spectral Width	dl	-		1	nm	
SMSR	SMSR	30		-	dB	
Average Output Power	P _o	-6		-1	dBm	2
Disabled Power	P _{off}	-		-30	dBm	2
Extinction Ratio	ER	6		-	dB	2
Minimum OMA-TDP (10G Ethernet)	OMAt _{dp}	-5.2		-	dBm	3
Eye Mask 1 (SONET/SDH)		GR-253-CORE/ITU-T G.691				2
Eye Mask 2 (10G Ethernet)		IEEE802.3ae				3
Generation Jitter 1 (20kHz - 80MHz)		-		0.15	UIp-p	2,4
Generation Jitter 2 (4MHz - 80MHz)		-		0.1	UIp-p	2,4
RIN	RIN	-		-128	dB/Hz	
Optical Path						
Parameter	Symbol	Min	Typical	Max	Unit	Note
Chromatic Dispersion (SONET/SDH)	CD	-		6.6	ps/nm	
Operating Distance (10G Ethernet)		-		10	km	
Attenuation (SONET/SDH)		0		4	dB	
Channel Insertion Loss (10G Ethernet)		0		6	dB	
Maximum DGD (SONET/SDH)	DGD	-		30	ps	

Receiver Optical Interface						
Parameter	Symbol	Min	Typical	Max	Unit	Note
Operating Data Rate	-	9.95		11.30	Gb/s	1
Input Center Wavelength	l _{rc}	1260		1565	nm	
Overload	R _{ovl}	0.5		-	dBm	
Minimum Sensitivity	P _{min}	-	-18	-14.6	dBm	2
Sensitivity in OMA	OMA ₀	-		-12.6	dBm	3

Stressed Sensitivity in OMA	OMAst	-		-10.3	dBm	3
RX_LOS Assert Level	RLOSa	-25			dBm	
RX_LOS Deassert Level	RLOSd			-15	dBm	
RX_LOS Hysteresis	RLOSh	1		5	dB	
Optical Path Penalty	PN	-		1	dB	1
Optical Return Loss	ORL	14		-	dB	
Jitter Tolerance	JTL	GR-253-CORE/ITU-T G.783				

Notes:

1. Data rate tolerance
 - 10GBASE-LR/LW: typ.+/-100ppm
2. Measured at 10.3125Gbps,Non-framed PRBS2^31-1,NRZ
3. Measured by using InnoLight SFP+ evaluation board.

8. DIGITAL DIAGNOSTIC FUNCTIONS

The following digital diagnostic characteristics are defined over the Recommended Operating Environment unless otherwise specified. It is compliant to SFF8472 Rev10.2 with internal calibration mode. For external calibration mode please contact our sales staff.

Parameter	Symbol	Min.	Max	Unit	Notes
Temperature monitor absolute error	DMI_Temp	-3	3	degC	Over operating temp
Laser power monitor absolute error	DMI_TX	-3	3	dB	
RX power monitor absolute error	DMI_RX	-3	3	dB	-1dBm to -15dBm range
Supply voltage monitor absolute error	DMI_VCC	-0.1	0.1	V	Full operating range
Bias current monitor	DMI_Ibias	-10%	10%	mA	

Table 7: Digital diagnostic specification table

9. ELECTRICAL CHARACTERISTICS

The following electrical characteristics are defined over the Recommended Operating Environment unless otherwise specified.

Parameter	Symbol	Min.	Typical	Max	Unit	Notes
Data Rate		-	10.3125	-	Gbps	
Power Consumption		-	900	1200	mW	
Transmitter						
Single Ended Output Voltage Tolerance		-0.3	-	4	V	
common mode voltage tolerance		15	-	-	mV	
Tx Input Diff Voltage	VI	180		700	mV	
Tx Fault	VoL	-0.3		0.4	V	At 0.7mA
Data Dependent Input Jitter	DDJ			0.1	UI	
Data Input Total Jitter	TJ			0.28	UI	
Receiver						
Single Ended Output Voltage Tolerance		-0.3	-	4	V	
Rx Output Diff Voltage	Vo	300		850	mV	
Rx Output Rise and Fall Time	Tr/Tf	30			ps	20% to 80%
Total Jitter	TJ			0.7	UI	
Deterministic Jitter	DJ			0.42	UI	

Table 8: Electrical Characteristics

10. CONTROL AND STATUS I/O TIMING CHARACTERISTICS

Timing characteristics of control and status I/O are included in Table 8, which is also defined in SFF-8431.

Parameter	Symbol	Min	Max	Unit	Condition
TX Disable Assert Time	t _{off}		10	μs	Time from rising edge of TX Disable to when the optical output falls below 10% of nominal
TX Disable Negate Time	t _{on}		1	ms	Time from falling edge of TX Disable to when the modulated optical output rises above 90% of nominal
Time to initialize, including reset of TX_Fault	t _{init}		300	ms	From power on or negation of TX Fault using TX Disable
TX Fault Assert Time	t _{fault}		100	μs	Time from fault to TX fault on.
TX Disable to reset	t _{reset}	10		μs	Time TX Disable must be held high to reset TX_fault
LOS Assert Time	t _{loss_on}		100	μs	Time from LOS state to RX LOS assert
LOS Deassert Time	t _{loss_off}		100	μs	Time from non-LOS state to RX LOS deassert
Rate-Select Change Time	t _{ratesel}		10	μs	Time from rising or falling edge of Rate Select input until receiver bandwidth is in conformance with appropriate specification.
Serial ID Clock Rate	f _{serial_clock}		100	kHz	

Table 9: Timing Characteristics

11. MECHANICAL

Comply to SFF-8432 rev. 5.0, the improved Pluggable form factor specification.

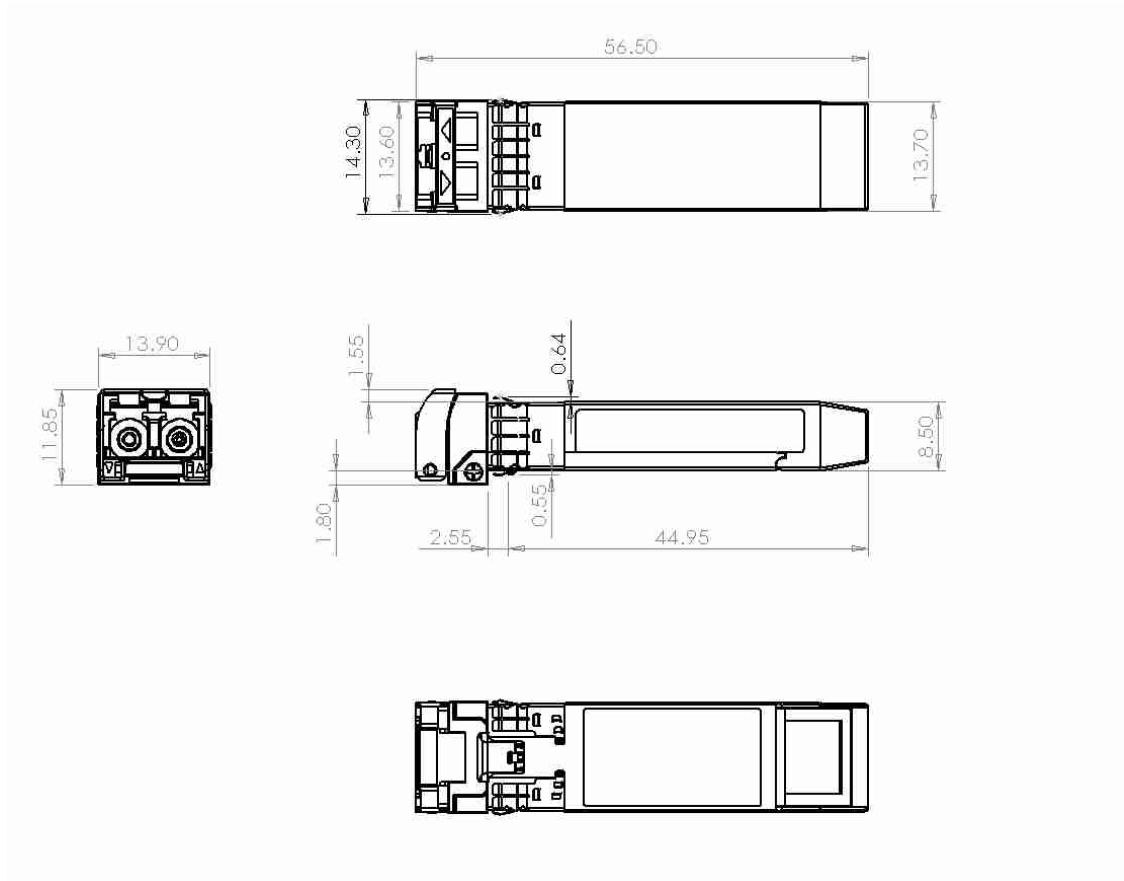

Table 10: Key Mechanical Dimensions

12. ESD

This transceiver is specified as ESD threshold 2kV for all electrical input pins, tested per MIL-STD-883, Method 3015.4 /JESD22-A114-A (HBM). However, normal ESD precautions are still required during the handling of this module. This transceiver is shipped in ESD protective packaging. It should be removed from the packaging and handled only in an ESD protected environment.

13. LASER SAFTY

This is a Class 1 Laser Product according to IEC 60825-1:1993:+A1:1997+A2:2001. This product complies with 21 CFR 1040.10 and 1040.11 except for deviations pursuant to Laser Notice No. 50, dated (July 26, 2001)

USA	China
InnoLight Technology Corp. Tel: (408) 838-8769 Fax: (408) 777-8091 Email: omok@innolight.com Address: Acom Campus, 3 Results Way, Cupertino, CA 95014	InnoLight Technology (Suzhou) Ltd. Tel: (0512) 8666-9288 Fax: (0512) 8666-9299 Email: jyang@innolight.com Address: 328 Xinghu Street,12- A3,Suzhou Industrial Park,Suzou,Jiangsu,215123,China

Contact Information